



STP08CDC596

8-BIT CONSTANT CURRENT LED SINK DRIVER WITH FULL OUTPUT DETECTION

- 8 CONSTANT CURRENT OUTPUT CHANNELS
- ADJUSTABLE OUTPUT CURRENT THROUGH ONE EXTERNAL RESISTOR
- OPEN AND SHORT LINE, SHORT TO GND, SHORT TO V-LED SUPPLY ERROR DETECTION
- SERIAL DATA IN/PARALLEL DATA OUT
- SERIAL OUT CHANGE STATE ON THE FALLING EDGES OF CLOCK
- OUTPUT CURRENT: 20-120 mA
- 25 MHz CLOCK FREQ.

DESCRIPTION

The STP08CDC596 is a monolithic, medium-voltage, low current power 8-bit shift register designed for LED panel display. The STP08CDC596 contains a 8-bit serial-in, parallel-out shift register that feeds a 8-bit D-type storage register. In the output stage, eight regulated current sources were designed to provide 15-120mA constant current to drive the LEDs.

The STP08CDC596 contains the built-IN error detection feature. The device performs this additional function without any increase of the pin number and any change of the pin function, if compared to the standard device without error detection. Consequently, choosing this device does not mean to change the footprint on the board. To perform this functionality mode, the device needs a digital key coming from the Microprocessor. The STP08CDC596 is able to detect: open and short on the LED line, short to

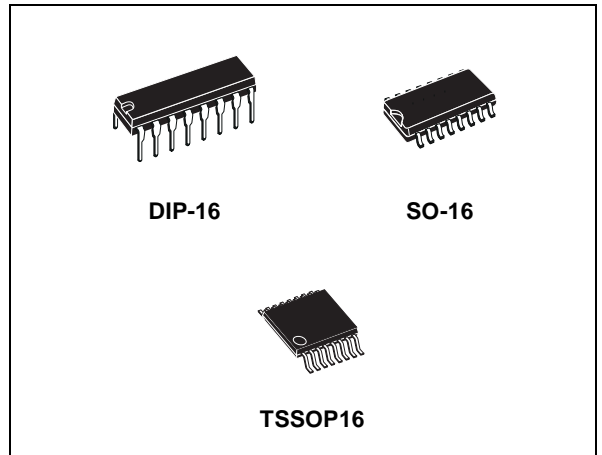

GND, short to Led voltage supply. The data mapping of output channels status detection is provided by a feedback from the serial output to the Microprocessor.

Trough an external resistor, users may adjust the STP08CDC596 output current, controlling the light intensity of LEDs.

The STP08CDC596 guarantees 16V output driving capability, allowing users to connect more LEDs in series. The high clock frequency, 25 MHz, also satisfies the system requirement of high volume data transmission.

The device is offered in DIP-16, SO-16 and TSSOP-16 packages.

The STP08CDC596 is well suitable for traffic display signs where the detection feature is strongly required.

Table 1: Order Codes

Type	Temp. Range	Package	Comments
STP08CDC596B1	-40°C to 125°C	DIP-16	25 part per tube
STP08CDC596M	-40°C to 125°C	SO-16 (Tube)	50 parts per tube
STP08CDC596MTR	-40°C to 125°C	SO-16 (Tape & Reel)	2500 parts per reel
STP08CDC596TTR	-40°C to 125°C	TSSOP16 (Tape & Reel)	2500 parts per reel

Table 2: Current Accuracy

Output Voltage	Current accuracy		Output Current
	Between bits	Between ICs	
≥ 0.7V	TYP. ± 3%	± 10%	20 to 120 mA

Figure 1: Pin Connection

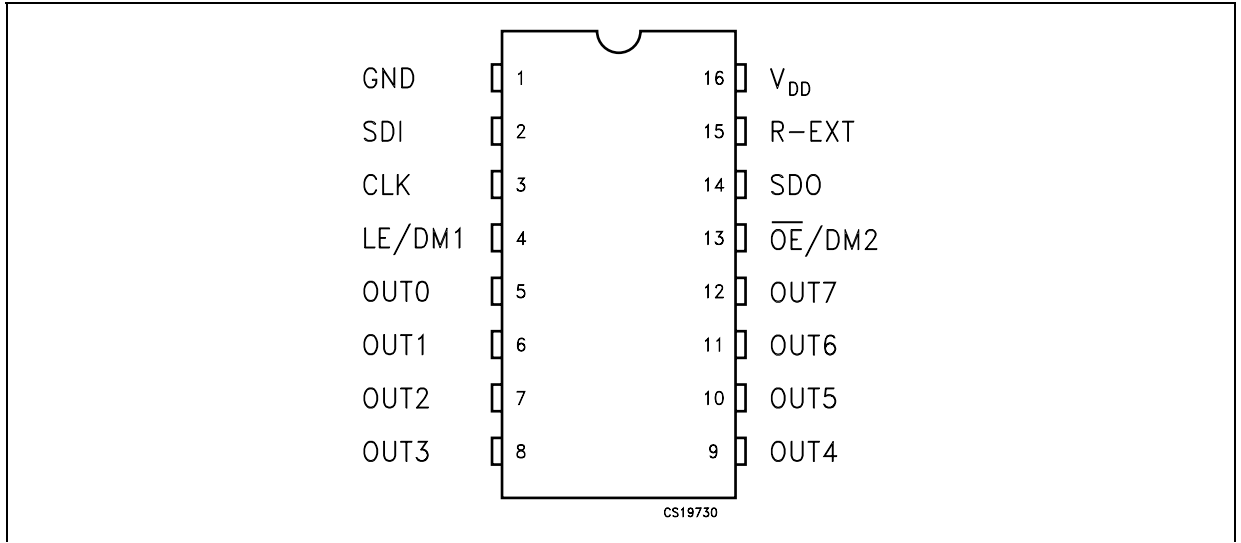

Table 3: Pin Description

PIN N°	Symbol	Name and Function
1	GND	Ground Terminal
2	SDI	Serial data input terminal
3	CLK	Clock input terminal
4	LE/DM1	Latch input terminal
5-12	OUT 0-7	Output terminal
13	OE/DM2	Output enable input terminal (active low)
14	SDO	Serial data out terminal
15	R-EXT	Constant Current programming
16	V _{DD}	5V Supply voltage terminal

Table 4: Absolute Maximum Ratings

Symbol	Parameter	Value	Unit
V _{DD}	Supply Voltage	0 to 7	V
V _O	Output Voltage	-0.5 to 16	V
I _O	Output Current	120	mA
V _I	Input Voltage	-0.4 to V _{DD} +0.4	V
I _{GND}	GND Terminal Current	980	mA
f _{CLK}	Clock Frequency	25	MHz
T _{OPR}	Operating Temperature Range	-40 to +125	°C
T _{STG}	Storage Temperature Range	-55 to +150	°C

Absolute Maximum Ratings are those values beyond which damage to the device may occur. Functional operation under these condition is not implied.

Table 5: Thermal Data

Symbol	Parameter	DIP-16	SO-16	TSSOP16	Unit
$R_{thj-amb}$	Thermal Resistance Junction-ambient	90	125	140	°C/W

Table 6: Recommended Operating Conditions

Symbol	Parameter	Test Conditions	Min.	Typ.	Max.	Unit
V_{DD}	Supply Voltage		3.3		5.5	V
V_O	Output Voltage				16.0	V
I_O	Output Current	OUTn	15		120	mA
I_{OH}	Output Current	SERIAL-OUT			+1	mA
I_{OL}	Output Current	SERIAL-OUT			-1	mA
V_{IH}	Input Voltage		$0.7V_{DD}$		$V_{DD}+0.3$	V
V_{IL}	Input Voltage		-0.3		$0.3V_{DD}$	V
t_{wLAT}	LE/DM1 Pulse Width	$V_{DD} = 3.0$ to $3.6V$		10	20	ns
t_{wCLK}	CLK Pulse Width			10	20	ns
t_{wEN}	OE/DM2 Pulse Width (1)			120	400	ns
$t_{SETUP(D)}$	Setup Time for DATA			5	20	ns
$t_{HOLD(D)}$	Hold Time for DATA			4	15	ns
$t_{SETUP(L)}$	Setup Time for LATCH			8	15	ns
f_{CLK}	Clock Frequency (2)					25

(1) If the device is connected in cascade, it may not be possible to achieve the maximum data transfer. Please consider the timings carefully.

(2) In normal mode the OE/DM2 must remain low at least two clock cycles.

Table 7: Electrical Characteristics ($V_{DD}=5V$, $T = 25^{\circ}C$, unless otherwise specified.)

Symbol	Parameter	Test Conditions	Min.	Typ.	Max.	Unit
V_{IH}	Input Voltage High Level		$0.7V_{DD}$		V_{DD}	V
V_{IL}	Input Voltage Low Level		GND		$0.3V_{DD}$	V
I_{OH}	Output Leakage Current	$V_{OH} = 16V$			10	μA
V_{OL}	Output Voltage (Serial-OUT)	$I_{OL} = 1mA$			0.4	V
V_{OH}	Output Voltage (Serial-OUT)	$I_{OH} = -1mA$	$V_{DD}-0.4V$			V
I_{OL1}	Output Current	$V_O = 0.7V$ $R_{EXT} = 910\ \Omega$	18.8	20.9	24.00	mA
I_{OL2}		$V_O = 0.7V$ $R_{EXT} = 360\ \Omega$	46.00	51.5	56.5	mA
ΔI_{OL1}	Output Current Error between bit (All Output ON)	$V_O = 0.7V$ $R_{EXT} = 910\ \Omega$		± 2	± 5	%
ΔI_{OL2}		$V_O = 0.7V$ $R_{EXT} = 360\ \Omega$		± 1	± 4	%
$R_{SIN(up)}$	Pull-up Resistor		150	300	600	K Ω
$R_{SIN(down)}$	Pull-down Resistor		100	200	400	K Ω
$I_{DD(OFF1)}$	Supply Current (OFF)	$R_{EXT} = OPEN$ OUT 0 to 7 = OFF		0.45	0.7	mA
$I_{DD(OFF2)}$		$R_{EXT} = 910\ \Omega$ OUT 0 to 7 = OFF		3.0	6.0	
$I_{DD(OFF3)}$		$R_{EXT} = 360\ \Omega$ OUT 0 to 7 = OFF		8.2	12.0	
$I_{DD(ON1)}$	Supply Current (ON)	$R_{EXT} = 910\ \Omega$ OUT 0 to 7 = ON		3.1	6.2	
$I_{DD(ON2)}$		$R_{EXT} = 360\ \Omega$ OUT 0 to 7 = ON		8.4	12.8	

Table 8: Switching Characteristics ($V_{DD}=3.3$ to $5.5V$, $T = 25^{\circ}C$, unless otherwise specified.)

Symbol	Parameter	Test Conditions	Min.	Typ.	Max.	Unit
t_{PLH1}	Propagation Delay Time, CLK-OUTn, LE/DM1 = H, OE/DM2 = L	$V_{DD} = 3 V$ $V_{IH} = V_{DD}$ $V_{IL} = GND$ $C_L = 13pF$		180	280	ns
t_{PLH2}	Propagation Delay Time, LE/DM1-OUTn, OE/DM2 = L	$I_O = 40mA$ $R_{EXT} = 470 \Omega$ $V_L = 3 V$ $R_L = 65 \Omega$		150	280	ns
t_{PLH3}	Propagation Delay Time, OE/DM2-OUTn, LE/DM1 = H			140	280	ns
t_{PLH}	Propagation Delay Time, CLK-SDO			25	35	ns
t_{PHL1}	Propagation Delay Time, CLK-OUTn, LE/DM1 = H, OE/DM2 = L			30	60	ns
t_{PHL2}	Propagation Delay Time, LE/DM1-OUTn, OE/DM2 = L			30	50	ns
t_{PHL3}	Propagation Delay Time, OE/DM2-OUTn, LE/DM1 = H			35	70	ns
t_{PHL}	Propagation Delay Time, CLK-SDO			30	40	ns
t_r	Output Rise Time			220		ns
t_f	Output Fall Time			20		ns

EQUIVALENT CIRCUIT OF INPUTS AND OUTPUTS

Figure 2: OE/DM2 Terminal

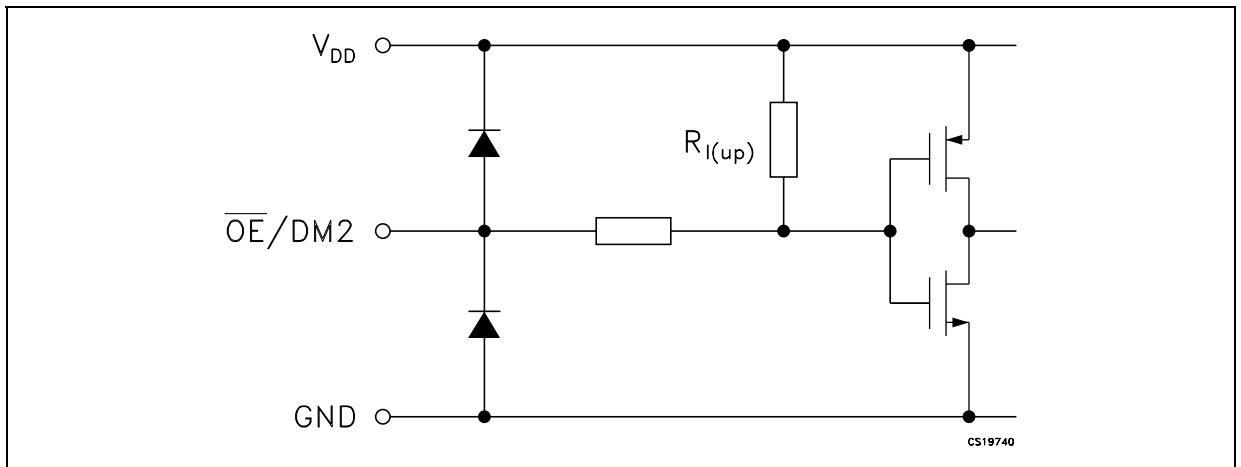

Figure 3: LE/DM1 Terminal

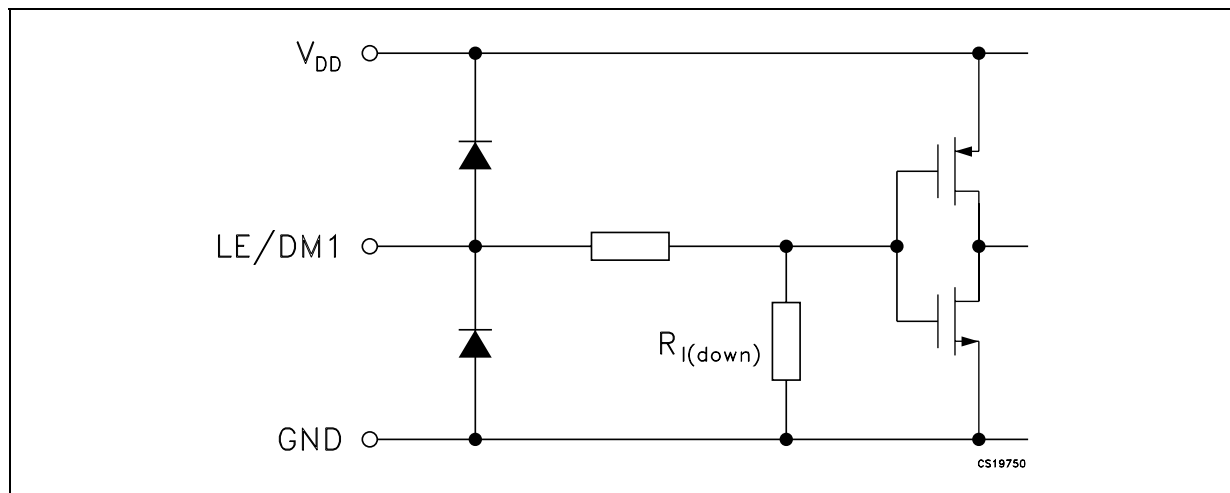

Figure 4: CLK, SDI Terminal

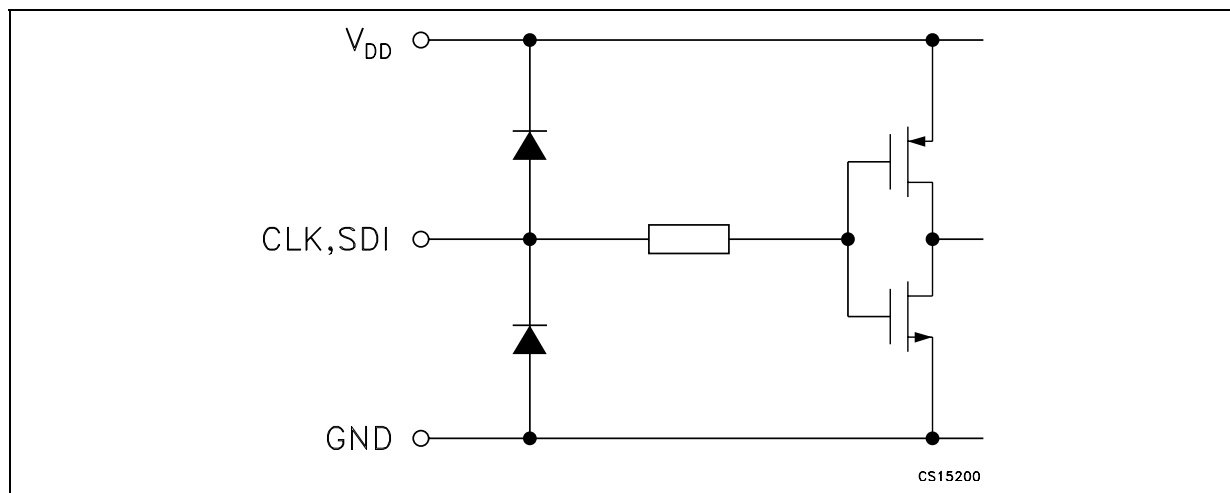

Figure 5: SDO Terminal

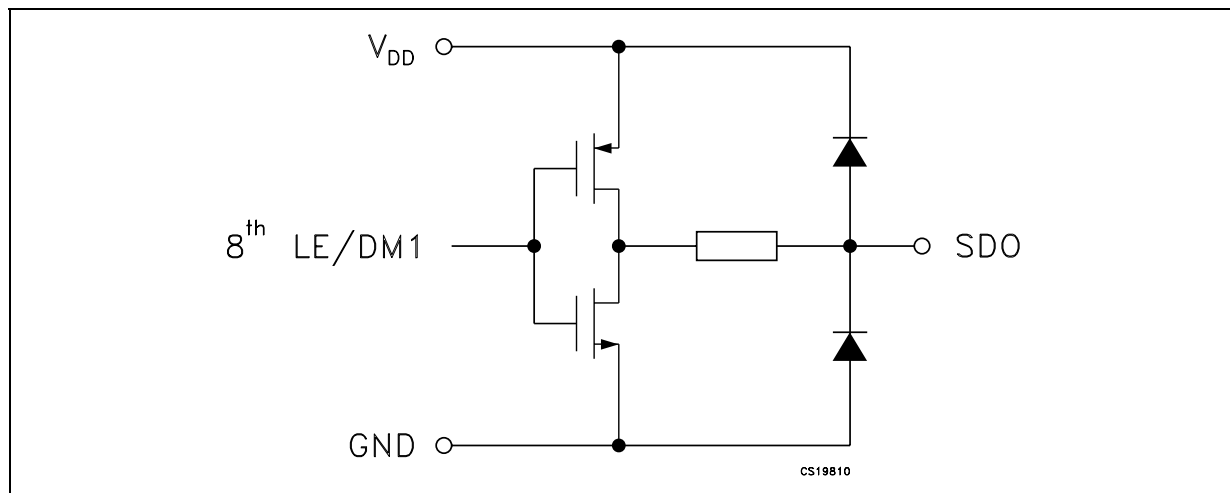

Figure 6: Block Diagram

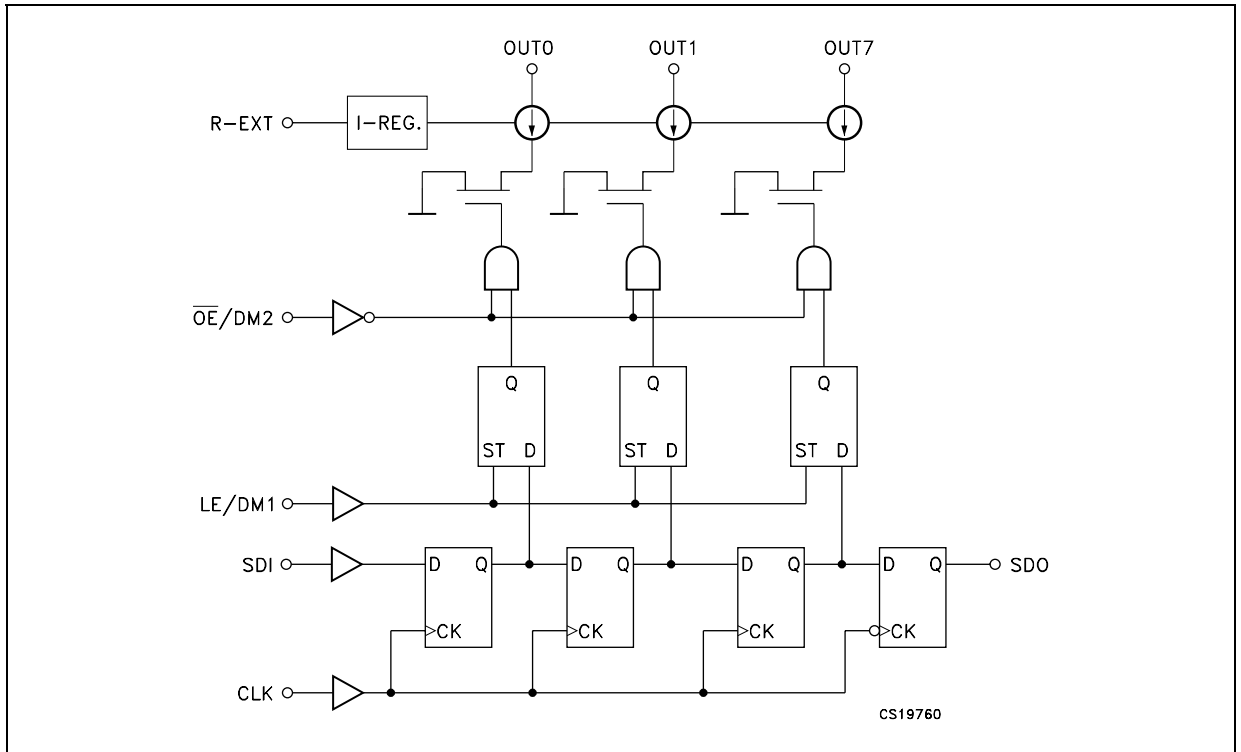
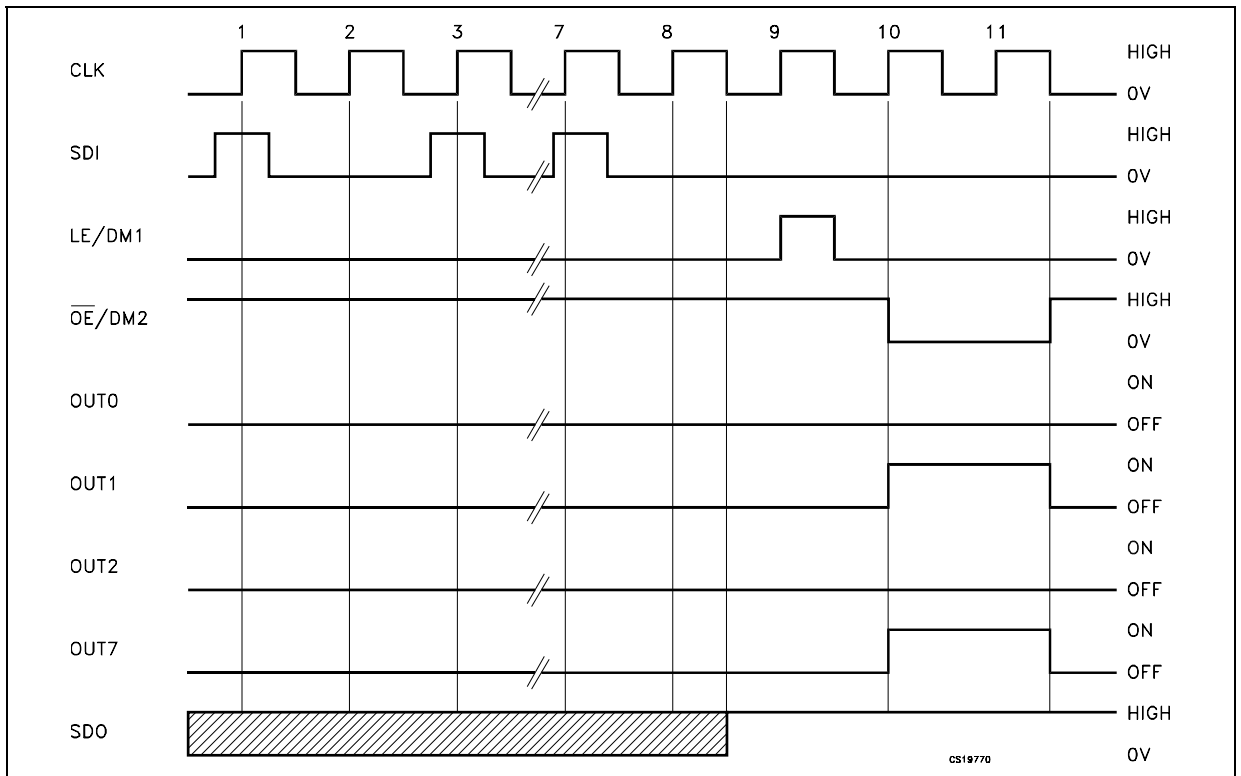

Figure 7: Timing Diagram



In normal mode the $\overline{OE}/DM2$ must remain low at least two clock cycles.

Figure 8: Clock, Serial-In, Serial-Out

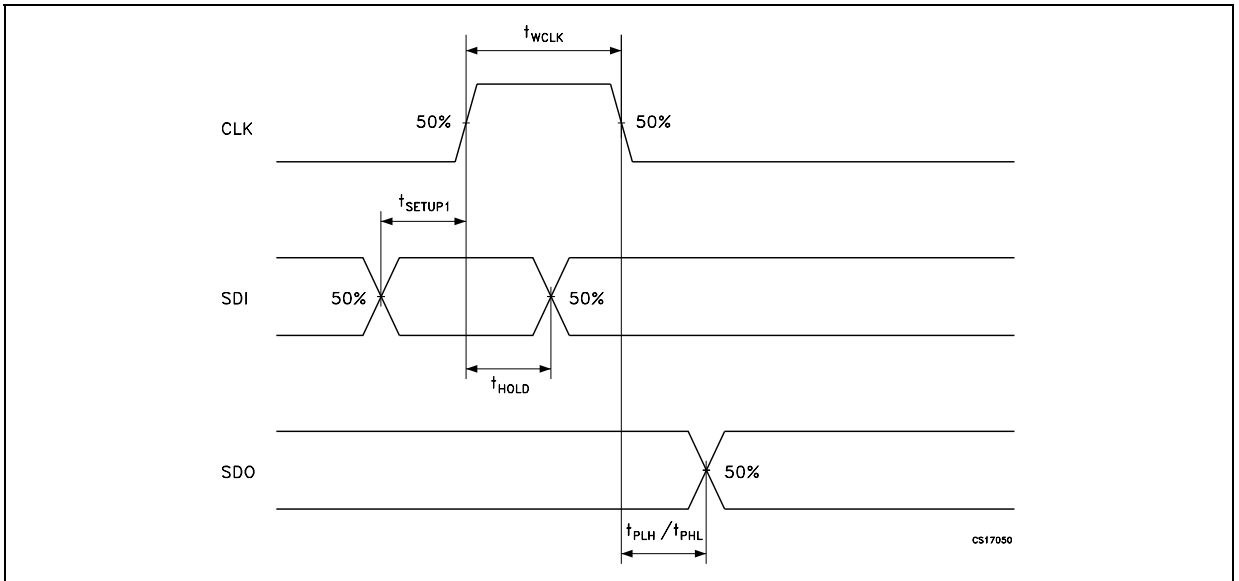

Figure 9: Clock, Serial-In, Latch, Enable, Outputs

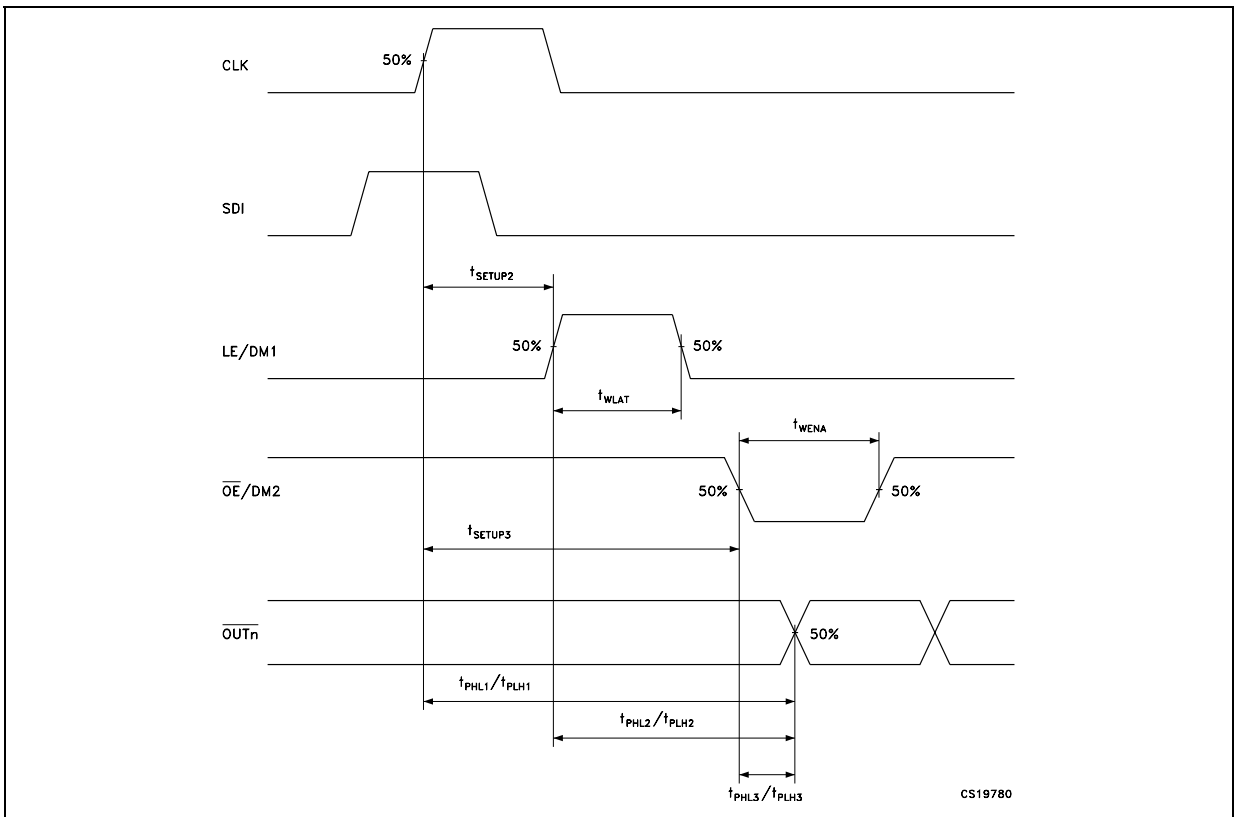
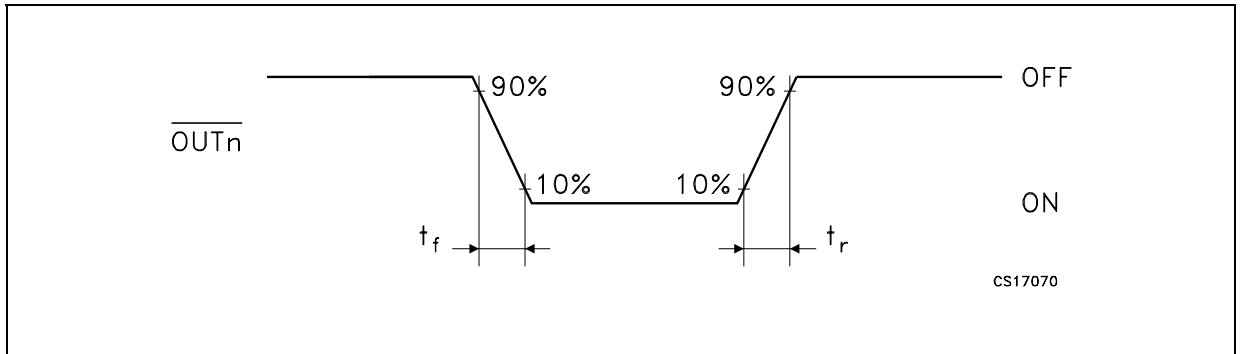

Figure 10: Outputs



TEST CIRCUIT

Figure 11: DC Characteristic

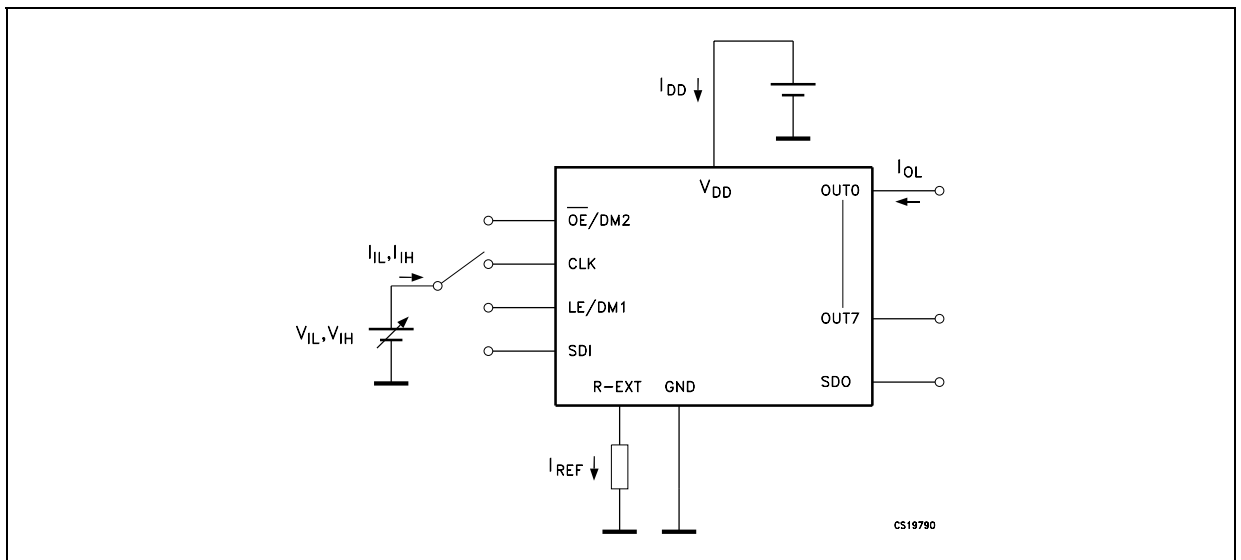
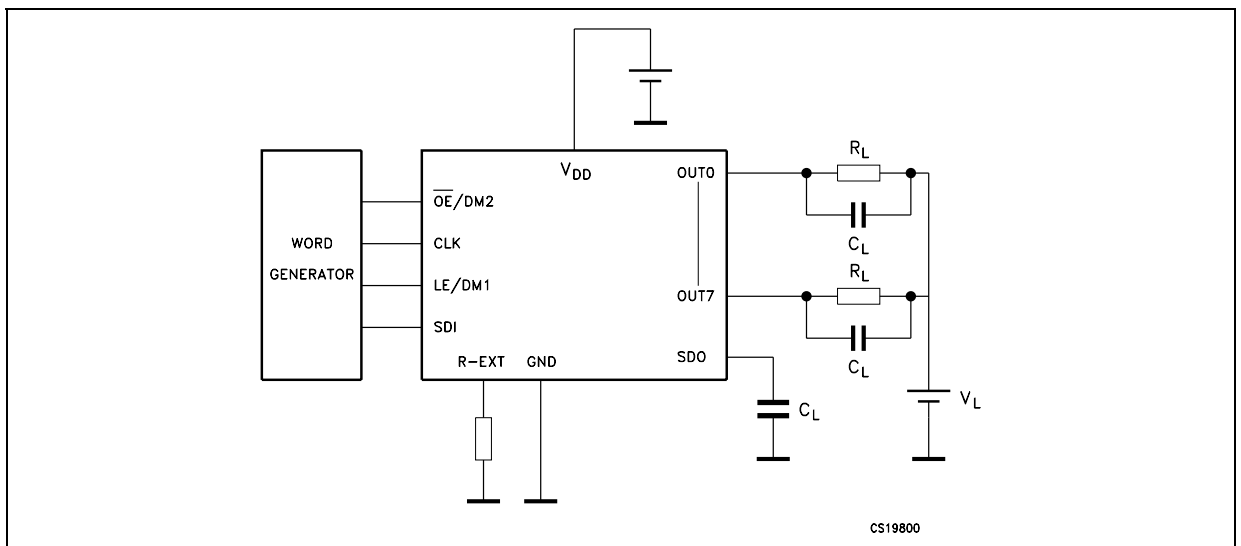

Figure 12: AC Characteristic



RUNNING THE DETECTION MODE

Phase One: “Entering In Detection Mode”

From the “Normal Mode” condition the device can switch to the “Error Detection Mode” by a logic

sequence on the OE/DM2 and LE/DM1 pins as showed in the following Table and Diagram:

Table 9: Entering In Detection Truth Table

CLK	1°	2°	3°	4°	5°
OE/DM2	H	L	H	H	H
LE/DM1	L	L	L	H	L

Figure 13: Entering In Detection Timing Diagram

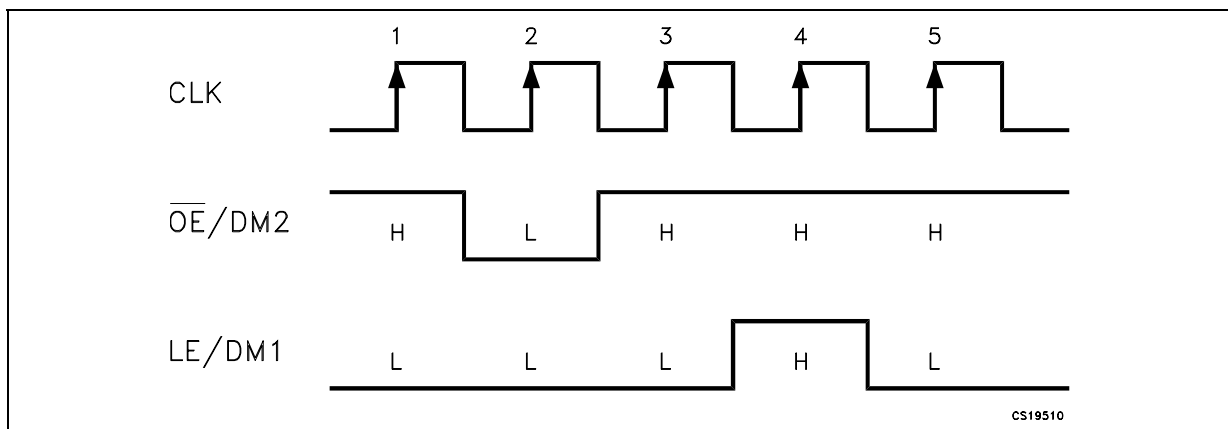

After these five CLK cycles the device goes into the “Error Detection Mode” and at the 6th rise front of CLK the SDI data are ready for the sampling.

Phase Two: “Error Detection”

The eight data bits must be set “1” in order to set ON all the outputs during the detection. The data are latched by LE/DM1 and after that the outputs are ready for the detection process. When the

Micro controller switches the OE/DM2 to LOW, the device drives the LEDs in order to analyze if an OPEN or SHORT condition has occurred.

Figure 14: Detection Diagram

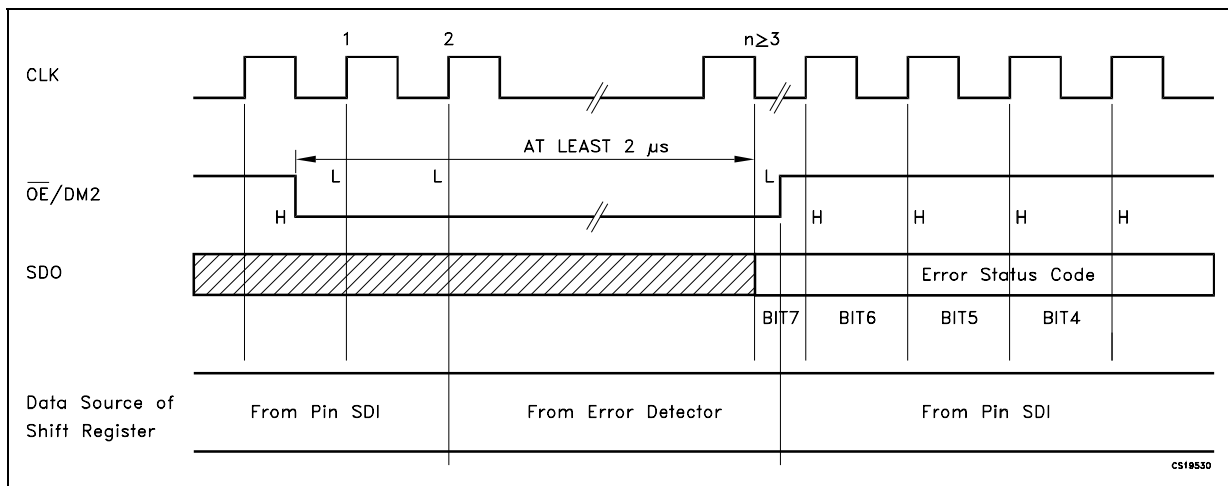

The LEDs status will be detected at least in 2 microseconds and after this time the micro controller puts OE in HIGH state and the output data detection result will go to the microprocessor via SDO.

The detection data format is the same of data in normal mode. As soon as all the detection data bits are available on the serial line, the device may go back to normal mode operation.

CONDITIONS IN ORDER TO GET A SUCCESSFULLY DETECTION CONDITION

Table 10: Detection Condition ($V_{DD} = 3.3$ to 5 V Temp. Range -40 to $85^{\circ}C$)

SW-1 or SW-3b	Open Line or Output Short to GND detected	$\implies I_{ODEC} \leq 0.5 \times I_O$	No error detected	$\implies I_{ODEC} \geq 0.5 \times I_O$
SW-2 or SW-3a	Short on LED or Short to V-LED detected	$\implies V_O \geq 2.4$ V	No error detected	$\implies V_O \leq 2.2$ V

where: I_O = the output current programmed by the R_{EXT} , I_{ODEC} = the detected output current in detection mode.

Figure 15: Detection Mode

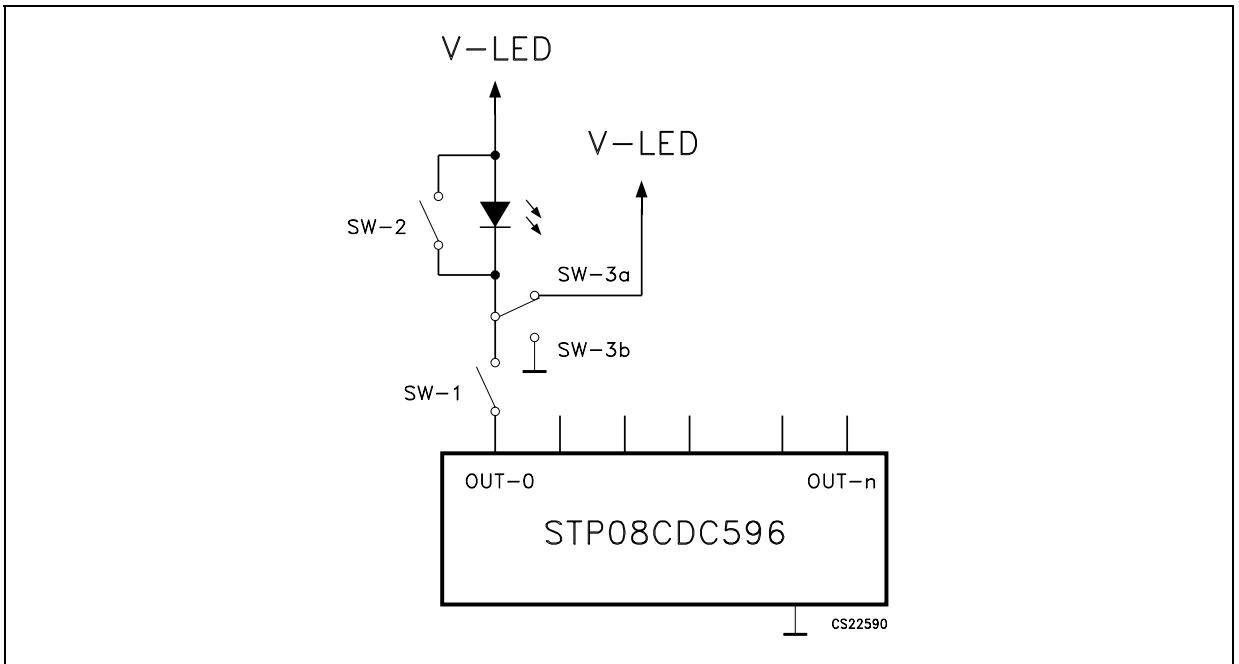

Phase Three: "Resuming to Normal Mode"

The sequence for re-entering in normal mode is showed in the following Table and diagram:

Table 11: Resuming to Normal Mode Timing Diagram

CLK	1°	2°	3°	4°	5°
OE/DM2	H	L	H	H	H
LE/DM1	L	L	L	L	L

Figure 16: Resuming to Normal Mode Timing Diagram

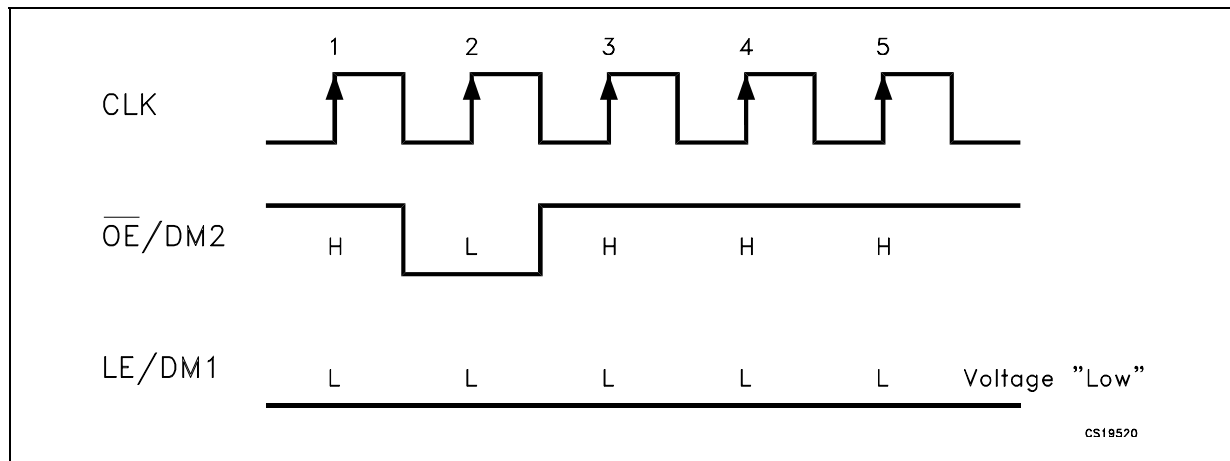

For proper device operation the "Entering in detection" sequence must be followed by a "Resume Mode" sequence, isn't possible to insert consecutive equal sequence.

Figure 17: Typical Output Current- R_{EXT} Resistor

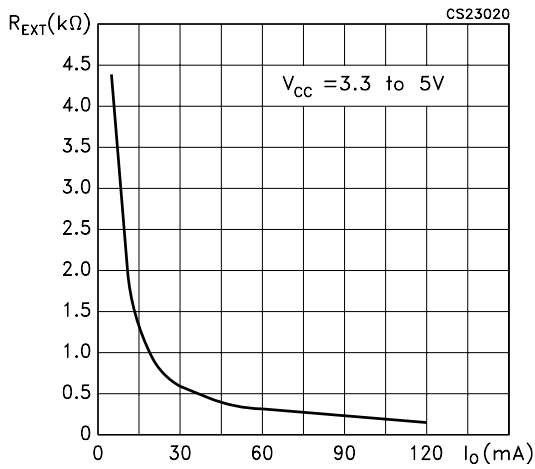

Figure 19: Typical Dropout Voltage vs Output Current

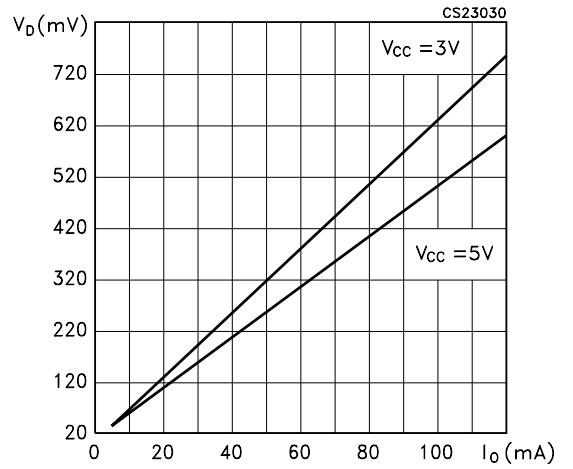

Figure 18: Power Dissipation vs Temperature Package

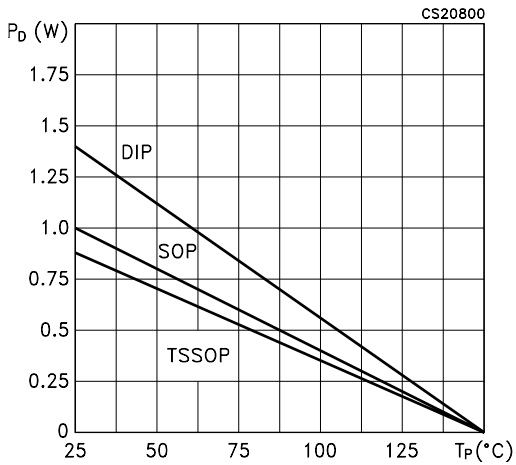

Figure 20: Typical Output Current vs $\pm\Delta I_{OL}$ (%)

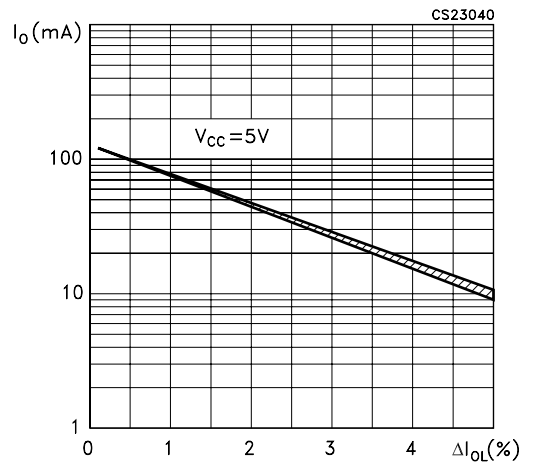
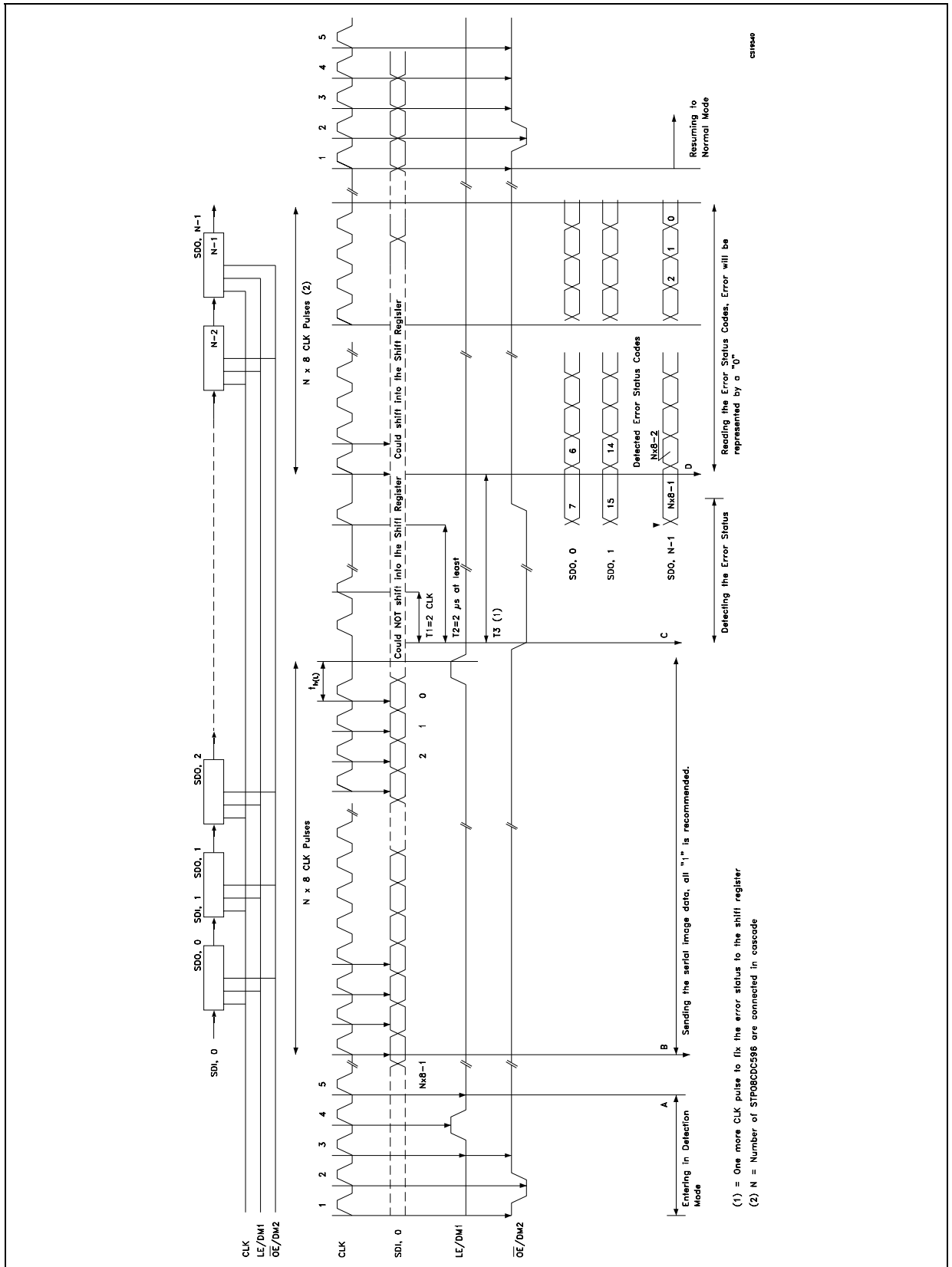
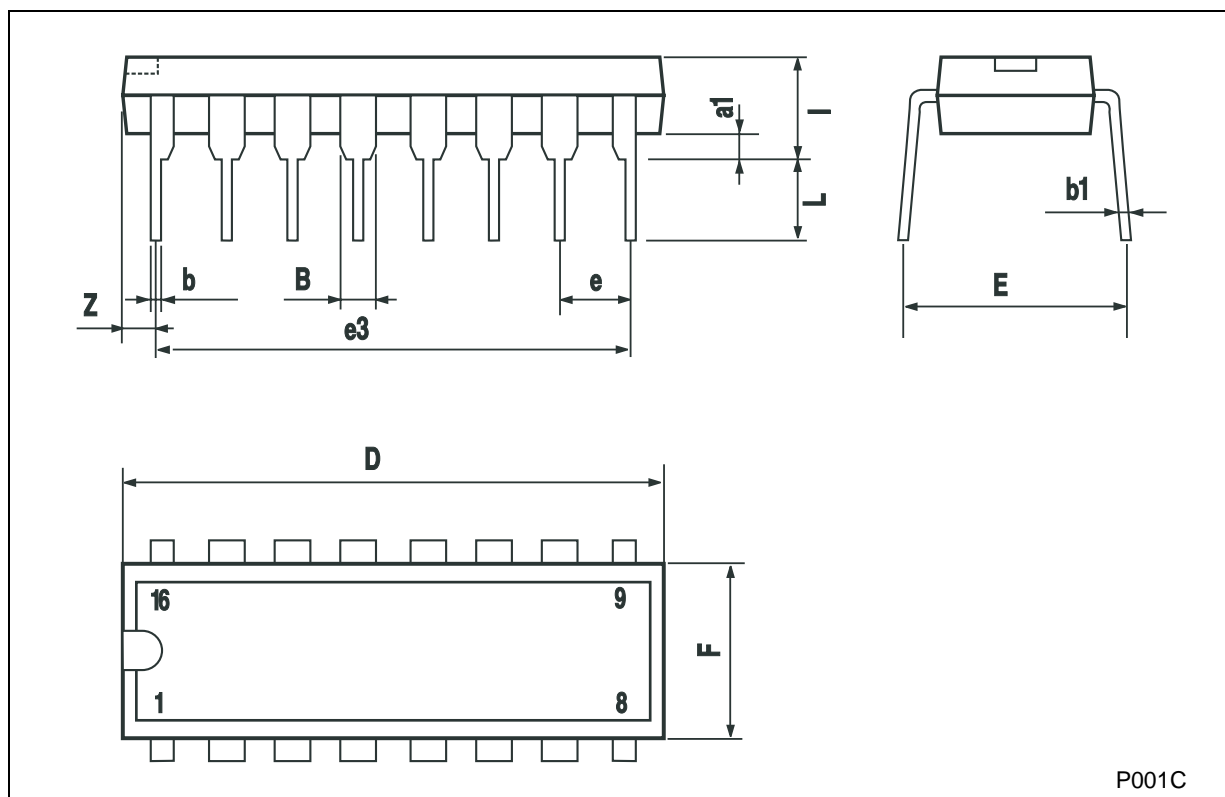

Figure 21: Timing example for Open and/or Short detection



Plastic DIP-16 (0.25) MECHANICAL DATA

DIM.	mm.			inch		
	MIN.	TYP	MAX.	MIN.	TYP.	MAX.
a1	0.51			0.020		
B	0.77		1.65	0.030		0.065
b		0.5			0.020	
b1		0.25			0.010	
D			20			0.787
E		8.5			0.335	
e		2.54			0.100	
e3		17.78			0.700	
F			7.1			0.280
I			5.1			0.201
L		3.3			0.130	
Z			1.27			0.050



P001C

SO-16 MECHANICAL DATA

DIM.	mm.			inch		
	MIN.	TYP.	MAX.	MIN.	TYP.	MAX.
A			1.75			0.068
a1	0.1		0.25	0.004		0.010
a2			1.64			0.063
b	0.35		0.46	0.013		0.018
b1	0.19		0.25	0.007		0.010
C		0.5			0.019	
c1	45° (typ.)					
D	9.8		10	0.385		0.393
E	5.8		6.2	0.228		0.244
e		1.27			0.050	
e3		8.89			0.350	
F	3.8		4.0	0.149		0.157
G	4.6		5.3	0.181		0.208
L	0.5		1.27	0.019		0.050
M			0.62			0.024
S	8° (max.)					

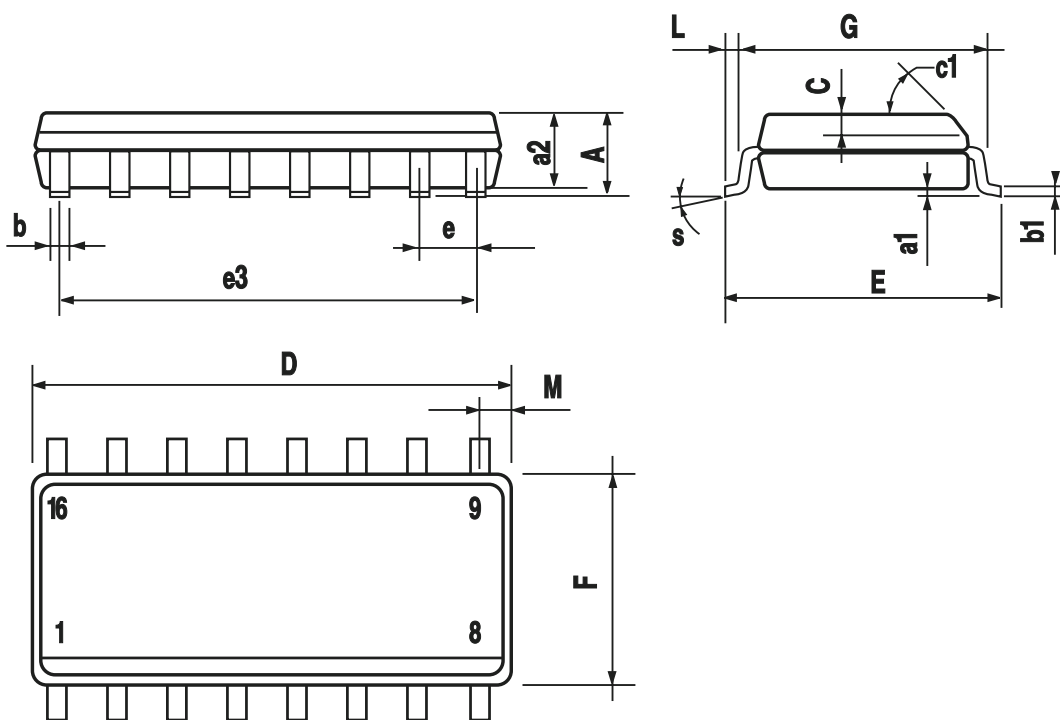

0016020D

TSSOP16 MECHANICAL DATA

DIM.	mm.			inch		
	MIN.	TYP	MAX.	MIN.	TYP.	MAX.
A			1.2			0.047
A1	0.05		0.15	0.002	0.004	0.006
A2	0.8	1	1.05	0.031	0.039	0.041
b	0.19		0.30	0.007		0.012
c	0.09		0.20	0.004		0.0079
D	4.9	5	5.1	0.193	0.197	0.201
E	6.2	6.4	6.6	0.244	0.252	0.260
E1	4.3	4.4	4.48	0.169	0.173	0.176
e		0.65 BSC			0.0256 BSC	
K	0°		8°	0°		8°
L	0.45	0.60	0.75	0.018	0.024	0.030

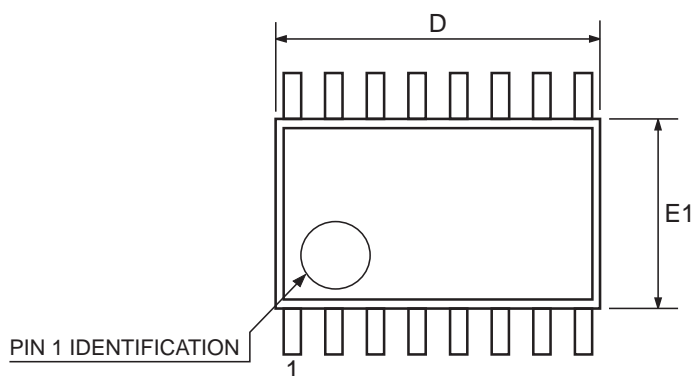
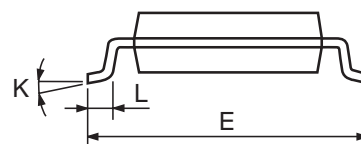
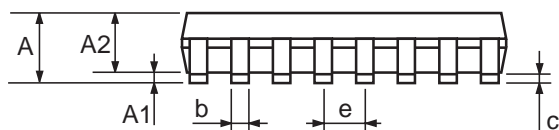

0080338D

Tape & Reel SO-16 MECHANICAL DATA

DIM.	mm.			inch		
	MIN.	TYP	MAX.	MIN.	TYP.	MAX.
A			330			12.992
C	12.8		13.2	0.504		0.519
D	20.2			0.795		
N	60			2.362		
T			22.4			0.882
Ao	6.45		6.65	0.254		0.262
Bo	10.3		10.5	0.406		0.414
Ko	2.1		2.3	0.082		0.090
Po	3.9		4.1	0.153		0.161
P	7.9		8.1	0.311		0.319

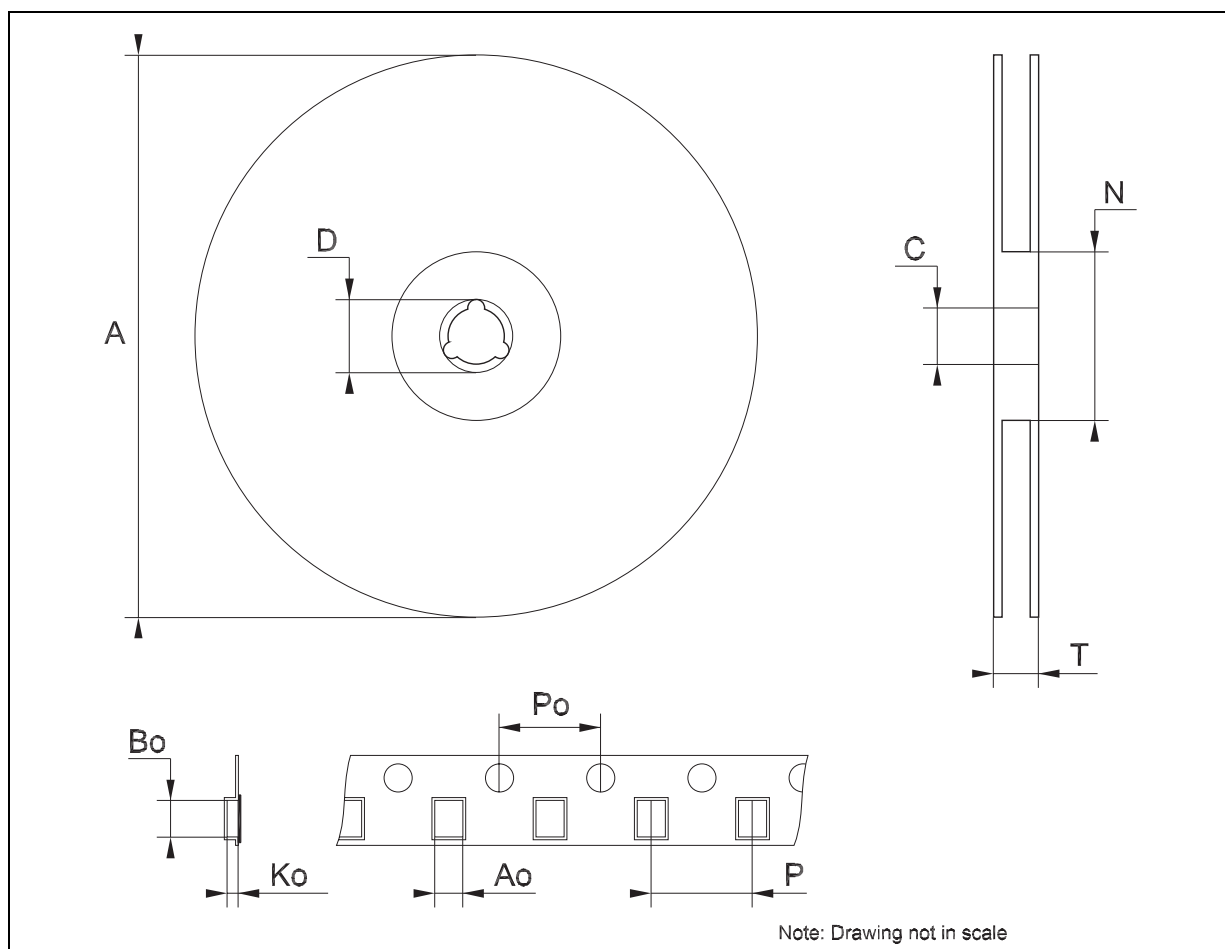

Tape & Reel TSSOP16 MECHANICAL DATA

DIM.	mm.			inch		
	MIN.	TYP	MAX.	MIN.	TYP.	MAX.
A			330			12.992
C	12.8		13.2	0.504		0.519
D	20.2			0.795		
N	60			2.362		
T			22.4			0.882
Ao	6.7		6.9	0.264		0.272
Bo	5.3		5.5	0.209		0.217
Ko	1.6		1.8	0.063		0.071
Po	3.9		4.1	0.153		0.161
P	7.9		8.1	0.311		0.319

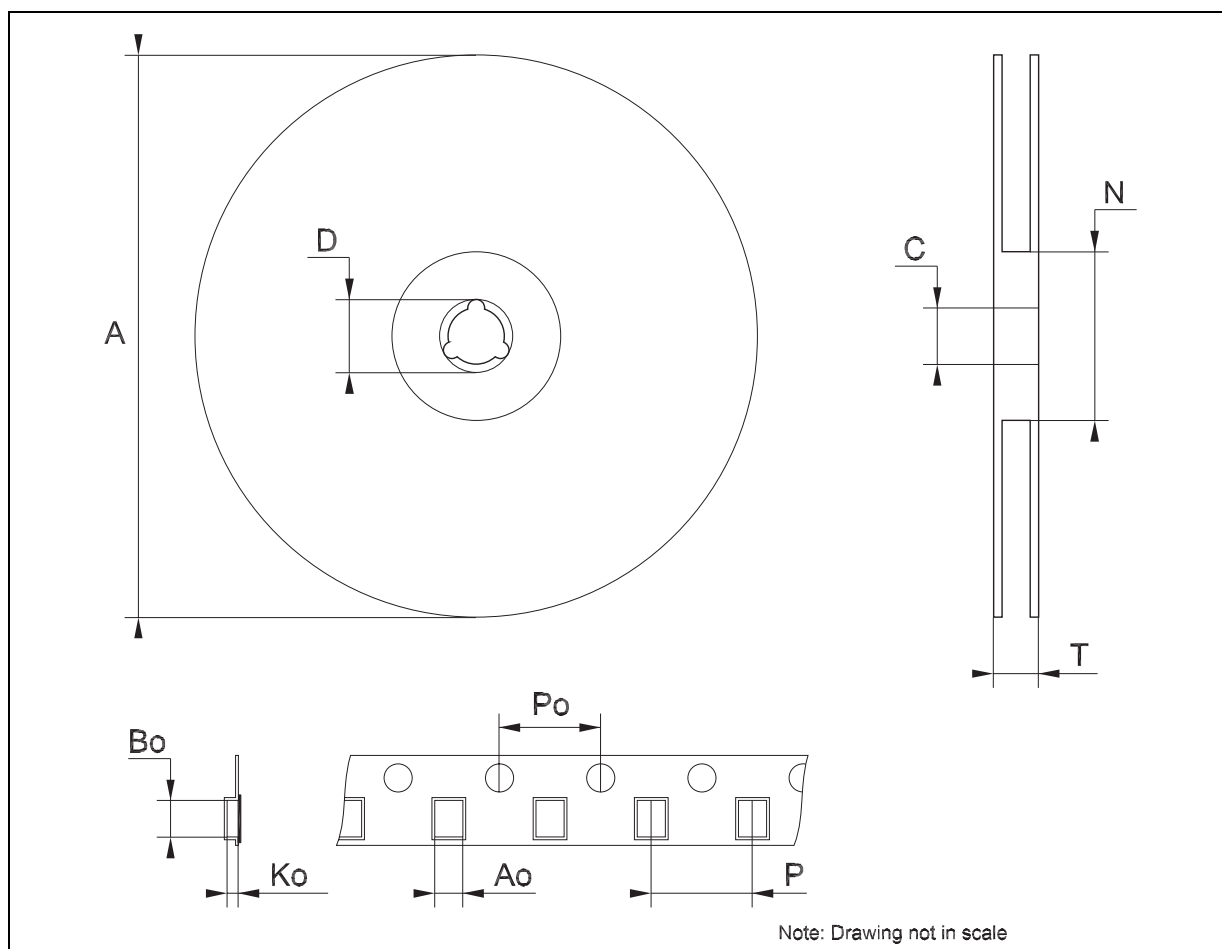

Table 12: Revision History

Date	Revision	Description of Changes
15-Jun-2005	1	First Release.
11-Oct-2005	2	Minor Revision

Information furnished is believed to be accurate and reliable. However, STMicroelectronics assumes no responsibility for the consequences of use of such information nor for any infringement of patents or other rights of third parties which may result from its use. No license is granted by implication or otherwise under any patent or patent rights of STMicroelectronics. Specifications mentioned in this publication are subject to change without notice. This publication supersedes and replaces all information previously supplied. STMicroelectronics products are not authorized for use as critical components in life support devices or systems without express written approval of STMicroelectronics.

The ST logo is a registered trademark of STMicroelectronics

All other names are the property of their respective owners

© 2005 STMicroelectronics - All Rights Reserved

STMicroelectronics group of companies

Australia - Belgium - Brazil - Canada - China - Czech Republic - Finland - France - Germany - Hong Kong - India - Israel - Italy - Japan - Malaysia - Malta - Morocco - Singapore - Spain - Sweden - Switzerland - United Kingdom - United States of America

www.st.com